

Prestressed Concrete Sleeper FS 150 / W 60 / W 54 for Rail fastening W

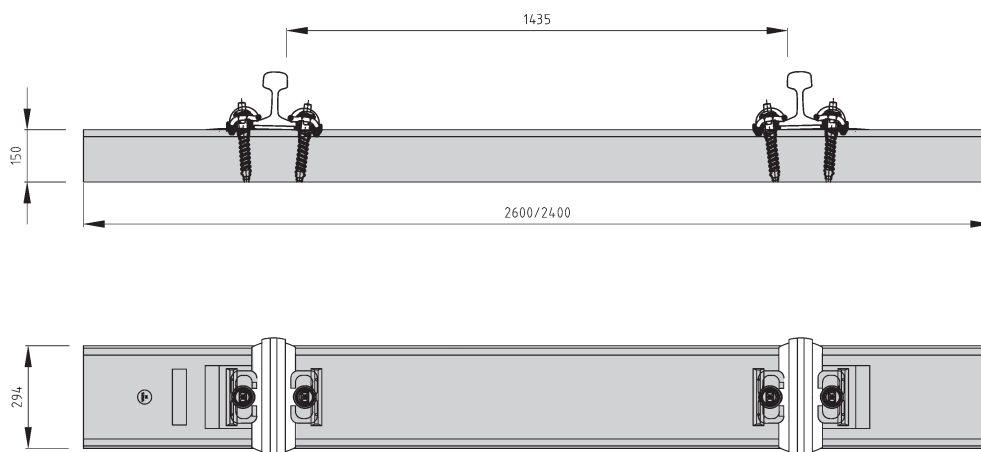

All dimensions in mm

Field of application:	Railway and Commuter Traffic
Permissible wheel set load:	225 kN
Rail inclination:	1:40 / 1:∞
Track gauge:	1435 mm
Rail fastening system:	W 14-T / W 21-T
Rail:	60 E 1 / 49 E 1 / 54 E 3
Weight:	With rail fastening system, approx. 270 kg

Can also be delivered with sleeper pads to lower the stress on the ballast. Sleeper pads provide vibration protection preserve the ballast under the tracks and lengthen the service life of the track.

Produced according to Deutsche Bahn standard DBS 918 143